

Model design of automatic defective product sorting system

Lubos Chovanec¹, Khanh Quang Duong^{2*}, Huong Thi Vuong², Lanh Thi Ngo², Nam Thi Nguyen², Dung Duy Tran², Son Thai Nguyen², Long Hai Pham²

¹Slovak University of Technology, Bratislava, Slovakia

²University of Transport Technology, Hanoi, Vietnam

Article info

Type of article:

Original research paper

*Corresponding author:

E-mail address:

khanhdq@utt.edu.vn

Received: 2/12/2022

Accepted: 18/12/2022

Published: 26/12/2022

Abstract: In industrial field, various automation techniques have been studied and applied to increase productivity, better accuracy and eliminate the human errors. This paper developed a model of the automatic defect sorting system to distinguish between qualified and defective products. By using image processing to detect the matching of captured images with the storage based samples, the system ensures products with different colours are correctly delivered to the designated box. In this study the detection of three types of products were tested by image processing provided by LabVIEW software. They are the cube face with full of red panels, the cube face with 3 of 4 red panels and the others. The test results of the system achieved approximately an accuracy of 96% under stable lighting conditions.

Keywords: Image processing, Sorting system, LabVIEW, PLC, OPC server.

1. Introduction

In recent times, various automatic sorting systems have been developed. The applications of sorting systems vary from agricultural products, consumer manufactured products, solid waste, etc.

Elatopo et al. designed a model and simulated the functionalities of an automatic sorting machine using a capacitive proximity sensor [1]. In order to achieve this developed automatic sorting methods, the images of the objects (i.e. plastics, wood and steel) were captured with the proximity sensor and the conveyor belt transports the material from one point to another one.

Sheth et al. proposed an automatic sorting system using machine vision [2]. In this paper, color based identification of the parts was studied and then objects were sorted according to different colors. After recognizing the color of the object, robotic arm will pick and place them accordingly.

A model using smart camera for quality

inspection and grading of good products was designed by Guo and colleagues [3]. In that, evolutionary learning process was developed for simplicity and for visual inspection of food products.

Soldatov et al. proposed a system using ultrasonic sensor fixed above conveyor to measure the height of the pallets [4]. According to the range of tolerance of heights on the surface of the pallet the system can detect defect, slope of pallet surface or foreign object on the pallet surface.

The aim of this research is to design a model of sorting system by image processing method which can detect and classify three types of cube's faces as shown in Figure 1.

- The first one with 4 red panels is considered as a perfect product with no defect.

- The second one with 3 of 4 red panels is considered as a product has slight defect.

- The last one with 2 red panels is considered

as a product has serious defect (any cube's faces with less than 3 red panels are considered as products has serious defect).

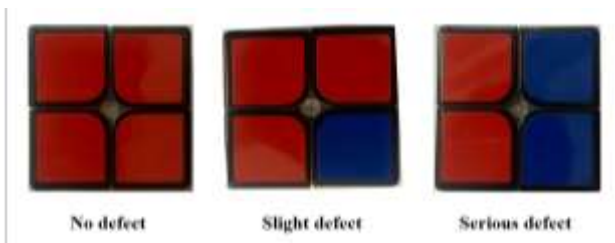

Figure 1. Three types of classified products

2. Design of the system

2.1. Block diagram

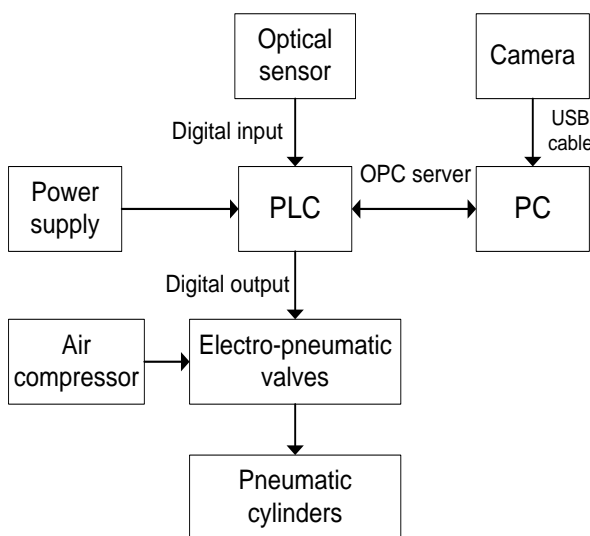

Figure 2. Block diagram of the sorting system

2.2. Working of the system

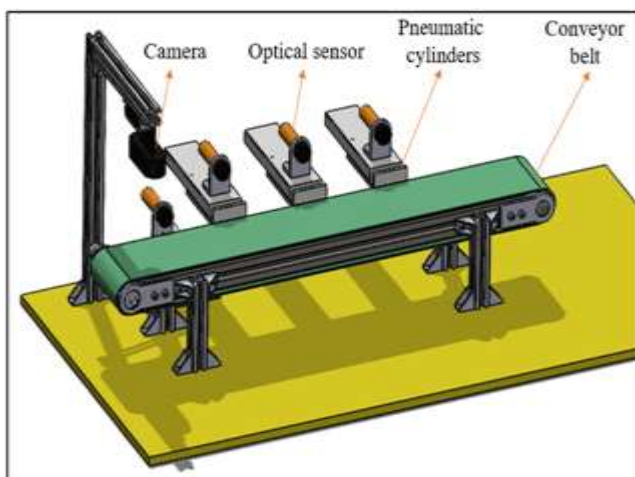

Figure 3. 3D drawing of the sorting system

Initially product is transported on conveyor belt. When optical sensor detects the presence of the particular product, digital signal is sent to PLC.

PLC stops the movement of conveyor belt for one second for capturing image with high resolution. Once image is captured, the software of the system (NI LabVIEW) will process on captured image and will generate signals according to classification. The signals will be sent back to PLC which controls the electro-pneumatic valves to classify products to the designated boxes.

3. Components of the system

3.1. PLC

PLC (Programmable Logic Controller) is an industrial controller that gets information from the inputs (push buttons, optical sensors), receives control signal from PC via OPC server and controls the actuator including conveyor belt controlled DC motor, electro-pneumatic valves.

In this model, Simatic S7-1200 CPU 1212C 6ES7212-1AE40-0XB0 was used. It has 8 digital inputs DC, 6 digital outputs DC, 2 analog inputs with the range from 0 to 10VDC and program/data memory of 75KB.

3.2. Pneumatic cylinders

Pneumatic cylinders are mechanical devices which use the power of compressed gas to produce a force in reciprocating linear motion. In our application they are used to move the products to designated boxes.



Figure 4. Pneumatic cylinder AirTAC TN10-75

3.3. Electro-pneumatic valves 5/2

Electro-pneumatic valves are valves that use electricity to control pneumatic cylinders.



Figure 5. Electro-pneumatic valves 5/2 STNC TG 2521-08

Table 1. Specification of electro-pneumatic valve 5/2 STNC T2512-08 [5]

Valve Type	5/2
Pressure	0.15-0.7 MPa
Usage voltage	24V

3.4. Optical sensor

Optical sensor E3F-DS30C4 is used in the model to detect the objects with the distance of 60-300mm, type of output is NPN.

3.5. Camera



Figure 6. Webcam Asus Streaming Kits C3

It will capture the image of object when signal is given to it by computer.

Table 2. Specification of camera [6]

Resolution	HD (1980 x 1080 pixels)
Number of frames per second	30 fps
Rotation	90 degree
Connection	USB 2.0

4. Software components

4.1. Image processing

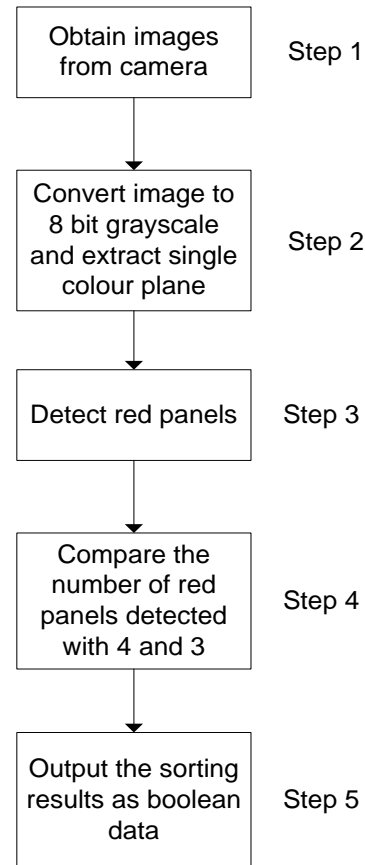

Figure 7. Five steps of image processing

The system uses NI LabVIEW software instead of WinCC provided by TIA Portal because of image processing to identify and classify products. The image processing in LabVIEW takes 5 steps:

(1) Obtain images from camera: the Vision Acquisition tool obtains images from camera that is connected to the PC via USB cable.

(2) Convert image to 8-bit grayscale: the IMAQ Create tool converts the image to 8-bit Grayscale and IMAQ Extract Single Color Plane tool extracts single color plane.

(3) Detect red panels: NI Vision Assistant software was used. It can be run in conjunction with NI LabVIEW.

Pattern Matching tool was used to detect the red panels. A template was set up as a red panel (through the process of Convert image to 8-bit grayscale and Extract single color plane will have the color as shown Figure 7).

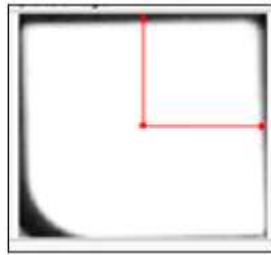

Figure 8. Template

Pattern Matching scans images of objects passing through the camera's scanning area, finds objects that have two elements: shaped like a cube's panel and red color. After finding the panels matching templates, Vision Assistant will output the number of matches. This number can have value from 0 to 4 (one face of cube has a maximum of 4 panels).

(4) Compare the number of red panels detected and output data: comparison blocks was chosen in LabVIEW to compare number of matches with 3 and 4.

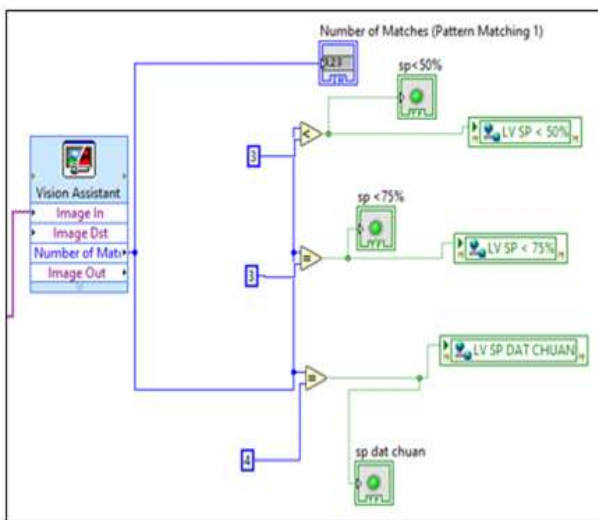

Figure 9. Compare block in LabVIEW

- If the number of matches is equal to 4, it means that the cube in the camera's scanning area is a perfect product with 4 red panels.

- If the number of matches is equal to 3, it means that the cube is a product has a slight defect with 3 red panels (more than 70% resemble perfect product).

- If the number of matches less than 3, the cube is a product has serious defect with 1 or 2 red panels (less than 70% resemble perfect product)

After performing the comparison, the comparison blocks set the boolean data to ON, there will be 3 boolean data corresponding to 3 types of products. They are sent to the PLC via the OPC server as data for the product classification process.

4.2. OPC server configuration

KEPserverEX6 software is used to configure OPC Server so that NI LabVIEW and TIA Portal can communicate with each other via boolean data, these data are used during programming of TIA Portal and NI LabVIEW.

4.3. Monitoring interface on NI LabVIEW

The Front panel of NI LabVIEW is used to display the monitoring interface.

At the monitoring interface, the operator can observe the image directly from the camera at the center of the screen. On the left panel is a control panel consisting of virtual buttons to control the system manually. On the right panel, the upper part is the result table of the sorted products, the lower part is the product classification result at the time where the cube is in the camera's scanning area.

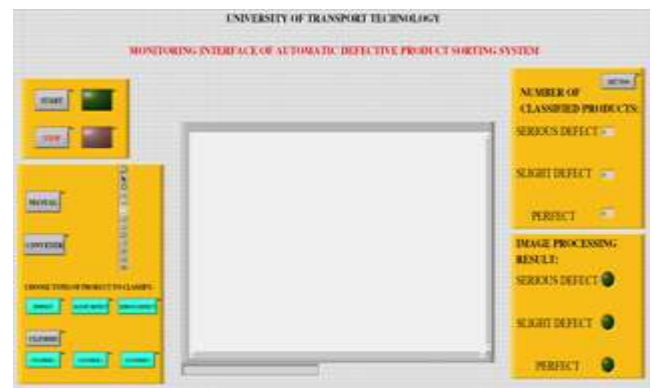

Figure 10. Monitoring interface in the Front panel of NI LabVIEW

5. Test results

As mentioned above, to test the accuracy of the sorting system, three types of products (perfect, slight perfect and serious perfect) were used as shown in Figure 1.

The total number of testing process was 100 for each type of product with different angles placed on conveyor belt.

Table 3. Result of image processing

	Perfect	Slight defect	Serious defect	Accuracy [percentage]
4 red panels	98	2	0	96
3 red panels	2	96	2	96
2 red panels	0	3	97	97

During the testing process some abnormal condition may happen such as no air pressure by compressor or no power supply. In case of no air pressure, the pneumatic cylinders would not work. In both cases, the classification system should be reset by pressing Start and Stop button simultaneously in at least 3 seconds.



Figure 2. Model of defective product sorting system

The product classification results achieve relatively high accuracy. It is stated that the results were not affected by the placement angle products on conveyor belt but by the following factors: conveyor speed (high conveyor speed will cause the camera not able to capture images with high resolution), lighting conditions (affects color detection).

In addition, the designed model encounters

some limits such as images processed only from one surface of the product, image processing cannot distinguish product with the surface too small because of low camera's resolution.

6. Conclusions

This research has developed a model of sorting system using image processing method. The model can detect an object that resembles a pre-configured pattern based on shape and colour.

The obtained results of this research could be to enhance the teaching and learning of mechatronics system engineering at different institutions, especially at the University of Transport Technology.

Acknowledgement

This paper was funded by the University of Transport Technology (UTT) under the grant number DTTD2021-07.

References

- [1]. B. I. Oladapo, V. A. Balogun, A .O. M. Adeoye, C. O. Ijagbemi, A. S. Oluwole, I. A. Daniyan, A. E. Aghor, A. P. Simeon (2016), Model design and simulation of automatic sorting machine using proximity sensor, *Engineering Science and Technology, an International Journal*, 19, 1452-1456.
- [2]. S. Sheth, R. Kher, R. Shah, P. Dudhat, P. Jani (2010), Automatic Sorting System Using Machine Vision. *Multi Disciplinary International Symposium on Control, Automation and Robotics*.
- [3]. Z. Guo, M. Zhang, D. J. Lee, T. Simons (2020), Smart Camera for Quality Inspection and Grading of Food Products, *Electronics*, 9 (505).
- [4]. A. I. Soldatov, A. A. Soldatov, P. V. Sorokin, E. L. Loginov, M. A. Kostina, O. A. Kozhemyak, S. I. Bortalevich (2016), System for Automatic Sorting of Pallets, *2016 International Siberian Conference on Control and Communications*.
- [5]. STNC T2512-08 datasheet
<https://stnc.co.th/en/products/pneumatics>

[6]. ASUS Webcam C3

<https://www.asus.com/accessories/streaming->

[kits/all-series/asus-webcam-c3/](https://www.asus.com/accessories/streaming-kits/all-series/asus-webcam-c3/)